

KingFlor[®]

Composite Steel Formwork System

KF57[®]

User and Installation Guide

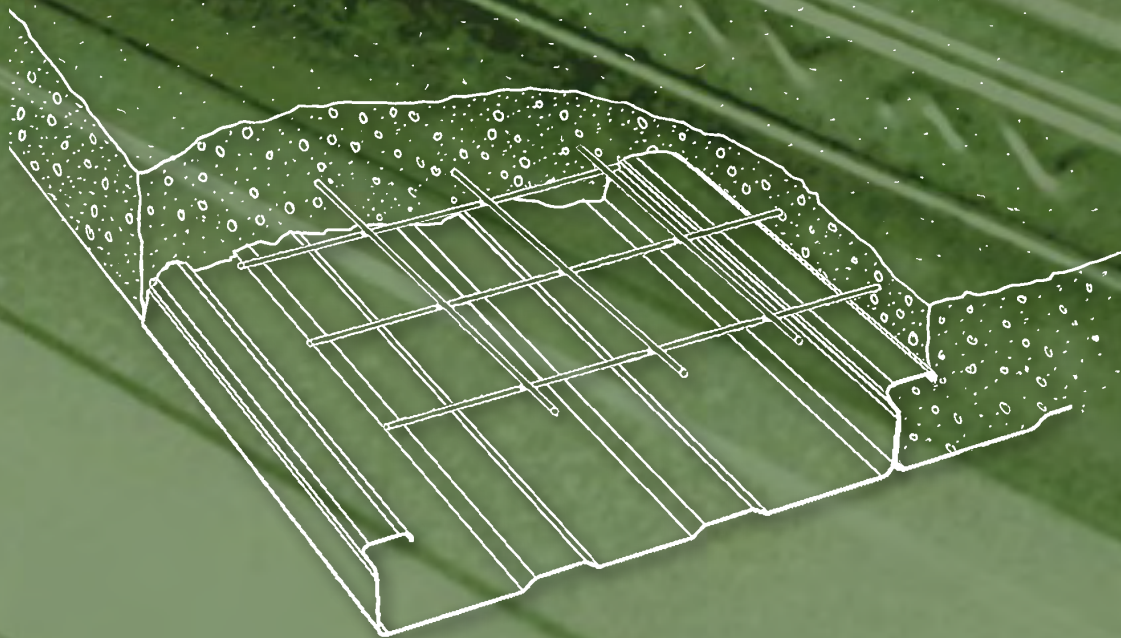

FINISH ON TOP WITH FIELDERS

Installing KF57®

Temporary Propping

If temporary propping is required (refer to the temporary propping tables), props should be placed at the correct centres prior to laying the KF57 sheets. Generally, timber or steel bearers with a minimum dimension of 75mm x 75mm are used on vertical props. The props should be installed so as to prevent settlement during loading by wet concrete and other construction loads.

Wide ply strips, of 300 mm wide, may be positioned above the header bearers to assist in dispersing the load and minimise any local deformation of the decking due to the headers.

Temporary props should only be removed after the slab has reached sufficient strength (at least 75% of the specified 28-day strength). The full design load may only be applied once the slab has achieved 28-day strength.

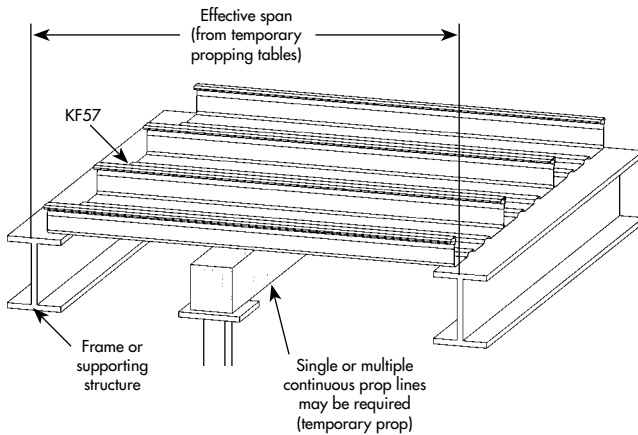

Laying KF57®

1. Place the KF57 sheet over the supports ensuring a minimum end bearing of 50mm. If supporting on a brick or masonry wall, provide a separating strip such as malthoid.
2. Engage subsequent sheets of KF57 by locking the larger female rib over the male rib as shown in the diagram below.

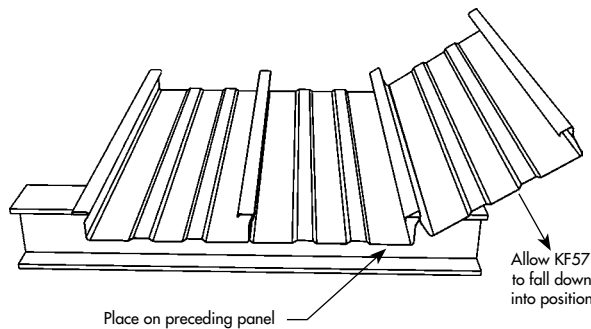

Fasteners and Locations

The decking must be secured to the supporting structure in order to avoid movement and excessive deflection during the pouring of concrete.

When fixing to a steel support structure, shot fired pins or self-drilling/tapping fasteners should be used. Provide one fastener in each pan at every support.

In the case of other support systems, such as brickwork, block work and concrete, the KF57 sheets must be temporarily held in place against wind and other effects until the concrete is poured.

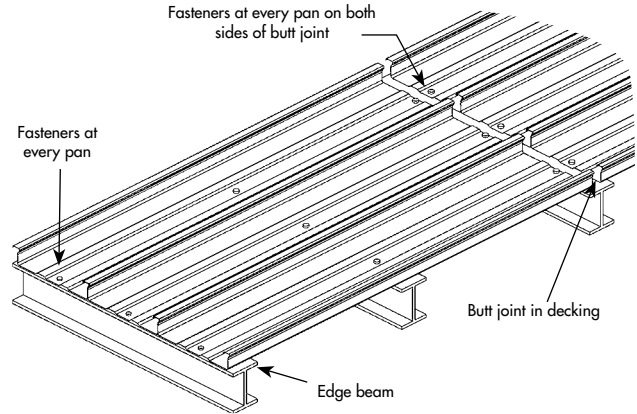

Edge-trim

Galvanised steel edge trims can be used for the retention of wet concrete to the correct level at the decked floor perimeters. KF57 edge-trim is usually shot-fired to the steel support structure or to the KF57 deck and the top of the trim is connected back to the decking with restraint straps at approximately 600mm centres using either pop-rivets or self-drilling screws.

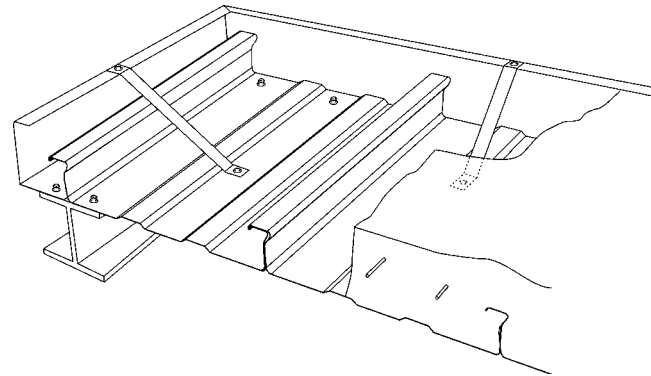

Reinforcement

Place all reinforcement in strict accordance with the structural engineer's drawings and specification.

Concrete placement

The specified grade of concrete and any chemical admixtures must be in strict accordance with AS 3600:2001 and the structural engineer's drawings and specification. The deck must be clear of any excess dirt, grease or debris as this inhibits bonding between the deck and concrete.

Ensure that concrete is applied evenly over the decking surface, as mounding of the wet concrete will cause excessive local loading.

Further information is available in the 'Specifying Fielders - KingFlor' Manual.

KF57® Features and Benefits

Fielders KF57 is a steel formwork solution suitable for composite concrete slabs in concrete and steel framed construction. KF57 is a light, easy to use, steel decking designed to combine with a concrete slab to produce a composite concrete slab system. KF57 incorporates an improved deck profile with deeper pan stiffeners.

KF57® Features and Benefits	
Feature	Benefit
Permanent composite formwork system	Once laid, KF57 becomes a permanent part of the slab, eliminating formwork stripping
Unique profile	Wide pans allow for clear access for in-floor services
Minimal propping	Less propping congestion and easy access to the underside of the slab
Supplied pre-cut to length, with 300mm wide cover	Quick to install
Reinforcing mesh can be laid directly on to the ribs	In many applications there is no need for mesh support stools
Closed rib profile, fully embedded in concrete slab	Major reduction in fire reinforcement

KF57® Material Specifications

KF57 is manufactured from G550 (550 MPa Yield Stress) steel with a Base Metal Thickness (BMT) of 0.60mm, 0.75mm and 1.00mm. The galvanised coating thickness is a Z350 (350 g/m²) in accordance with AS 1397:2001.



KF57® Material Specifications				
Material Properties		0.60 BMT	0.75 BMT	1.00 BMT
Mass Area –	Average mass of fitted deck per plan area (kg/m ²)	8.09	9.97	13.10
Mass Linear –	Mass of individual length (kg/m)	2.43	2.99	3.93
Zinc Coating (g/m ²) (Z350)		350	350	350
Yield Strength (MPa)		550	550	550

Note: KF57 is also available with Fielders patented Re-Lok corner embossments for superior composite slab performance. Please check with your local branch for details.

KF57[®] Temporary Propping Tables

KF57[®] Equally Spaced Props - Single Spans Maximum Spans (mm) for Deflection L/240

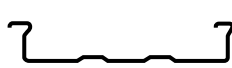

KF57[®]

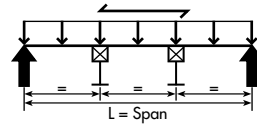

L/240

Dcs (mm)	Unpropped			1 Row of Props			2 Rows of Props		
	0.60 BMT	0.75 BMT	1.00 BMT	0.60 BMT	0.75 BMT	1.00 BMT	0.60 BMT	0.75 BMT	1.00 BMT
100	2,050	2,300	2,550	[5,200]	[5,600]	[6,150]	[7,250]	[7,750]	[8,550]
110	2,000	2,250	2,500	[5,000]	[5,400]	[5,950]	[7,000]	[7,500]	[8,250]
120	1,950	2,150	2,400	[4,850]	[5,250]	[5,800]	[6,850]	[7,350]	[8,050]
130	1,900	2,150	2,350	[4,750]	[5,150]	[5,700]	[6,650]	[7,150]	[7,900]
140	1,850	2,100	2,300	4,600	[5,000]	[5,550]	[6,500]	[7,000]	[7,700]
150	1,800	2,050	2,250	4,500	4,900	[5,450]	[6,400]	[6,850]	[7,550]
160	1,800	2,000	2,200	4,400	4,750	5,350	[6,250]	[6,700]	[7,400]
170	1,750	1,950	2,200	4,300	4,650	5,250	[6,150]	[6,600]	[7,250]
180	1,700	1,950	2,150	4,200	4,600	5,150	6,050	[6,500]	[7,150]
190	1,700	1,900	2,100	4,150	4,500	5,050	5,950	6,400	[7,050]
200	1,650	1,850	2,100	4,050	4,400	4,950	5,850	6,300	6,900
210	1,650	1,850	2,050	4,000	4,350	4,900	5,750	6,200	6,800
220	1,600	1,800	2,000	3,950	4,250	4,800	5,650	6,100	6,700
230	1,600	1,800	2,000	3,850	4,200	4,700	5,600	6,000	6,650
240	1,550	1,750	1,950	3,800	4,150	4,650	5,500	5,950	6,550
250	1,550	1,750	1,950	3,750	4,050	4,600	5,450	5,850	6,450

KF57[®] Equally Spaced Props - Two or More Spans Maximum Spans (mm) for Deflection L/240

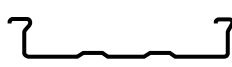

KF57[®]

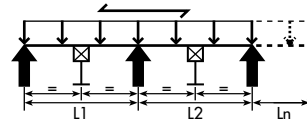

L/240

Dcs (mm)	Unpropped			1 Row of Props			2 Rows of Props		
	0.60 BMT	0.75 BMT	1.00 BMT	0.60 BMT	0.75 BMT	1.00 BMT	0.60 BMT	0.75 BMT	1.00 BMT
100	2,600	2,800	3,050	[4,900]	[5,250]	[5,800]	[7,400]	[7,900]	[8,550]
110	2,300	2,500	2,750	[4,750]	[5,100]	[5,650]	[7,150]	[7,700]	[8,250]
120	2,250	2,450	2,650	4,650	[5,000]	[5,500]	[6,950]	[7,500]	[8,050]
130	2,200	2,350	2,600	4,550	4,850	[5,350]	[6,800]	[7,300]	[7,900]
140	2,150	2,300	2,550	4,450	4,750	5,250	[6,650]	[7,150]	[7,700]
150	2,100	2,250	2,500	4,350	4,650	5,150	[6,500]	[7,000]	[7,550]
160	2,050	2,200	2,450	4,250	4,550	5,050	6,400	[6,850]	[7,400]
170	2,050	2,200	2,400	4,200	4,500	4,950	6,300	6,750	[7,250]
180	2,000	2,150	2,350	4,100	4,400	4,850	6,150	6,650	7,150
190	1,950	2,100	2,350	4,050	4,350	4,800	6,050	6,500	7,050
200	1,950	2,100	2,300	3,950	4,250	4,700	5,950	6,400	6,900
210	1,900	2,050	2,250	3,900	4,200	4,650	5,900	6,300	6,800
220	1,850	2,000	2,200	3,850	4,150	4,550	5,800	6,250	6,700
230	1,850	2,000	2,200	3,800	4,100	4,500	5,700	6,150	6,650
240	1,800	1,950	2,150	3,750	4,050	4,450	5,600	6,050	6,550
250	1,800	1,950	2,150	3,700	4,000	4,400	5,550	6,000	6,450

Temporary Propping Tables Notes

- The tables above denote maximum allowable centreline to centreline span in millimetres between permanent supports after temporary propping is removed.
- The practical limit for span to slab depth ratio is considered to be 35 for single span slabs, or 40 for continuous slabs. Values above these limits have been listed in brackets "[]". The use of the results in brackets must be confirmed with the structural engineer or a Fielders representative as the long term serviceability and composite performance of the resulting concrete slab may not be suitable for the project application.
- Allowance has been made for ponding of wet concrete due to decking deflection, density 2400kg/m³.
- Loading is considered in accordance with AS 1170.0:2002, AS 2327.1:2003, AS 3610:1995 with a Stage III construction live load allowance of 1.0kPa in accordance with AS 2327.1:2003 Appendix F.
- The requirements for Stage II & IV material stacking loads in accordance with AS 2327.1:2003 Appendix F are assumed to be zero.
- It is recommended that an experienced structural engineer design the composite slab to ensure sufficient capacity to meet strength and long term deflection requirements.
- The temporary propping tables have been prepared for a span/240 deflection criteria. A span/240 deflection is generally considered aesthetically satisfactory for exposed soffits.
- These tables are based upon effective section properties of the sheeting calculated in accordance to AS 4600:2005.
- Care must be exercised when placing concrete to avoid mounding.
- Wide ply strips, of 300 mm wide, shall be provided to prevent any concentrated loads being applied to the sheeting, particularly for exposed soffits, to avoid direct point loading of the sheet overlap ribs and unsupported edges of the sheeting.
- When using the table for two or more spans the adjacent spans should not differ in length by more than 5%.
- A maximum sheet length of 12m has been considered.
- A minimum bearing width of the permanent support has been considered to be 50mm.
- Fielders recommend a gauge of 1.00 mm BMT for exposed soffits in propped applications to avoid creasing of steel decking. Please contact your local KingFlor representative for further information.

KF57® Frame Propping - 1200mm Frame Size
Maximum Spans (mm) for Deflection L/240

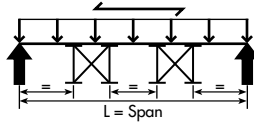

L/240

Dcs (mm)	1 Frame			2 Frame		
	0.60 BMT	0.75 BMT	1.00 BMT	0.60 BMT	0.75 BMT	1.00 BMT
100	[5,000]	[5,300]	[5,700]	[8,100]	[8,550]	[9,150]
110	[4,900]	[5,200]	[5,600]	[7,950]	[8,400]	[9,000]
120	[4,800]	[5,100]	[5,500]	[7,800]	[8,250]	[8,850]
130	[4,700]	[5,000]	[5,400]	[7,650]	[8,100]	[8,700]
140	4,600	4,900	[5,300]	[7,500]	[7,950]	[8,550]
150	4,500	4,800	5,200	[7,350]	[7,800]	[8,400]
160	4,500	4,700	5,100	[7,350]	[7,650]	[8,250]
170	4,400	4,700	5,000	[7,200]	[7,650]	[8,100]
180	4,400	4,600	5,000	[7,200]	[7,500]	[8,100]
190	4,300	4,500	4,900	[7,050]	[7,350]	[7,950]
200	4,300	4,500	4,800	[7,050]	[7,350]	[7,800]
210	4,200	4,400	4,800	6,900	7,200	[7,800]
220	4,200	4,400	4,700	6,900	7,200	7,650
230	4,100	4,300	4,700	6,750	7,050	7,650
240	4,100	4,300	4,600	6,750	7,050	7,500
250	4,000	4,300	4,600	6,600	7,050	7,500

KF57® Frame Propping - 1500mm Frame Size
Maximum Spans (mm) for Deflection L/240

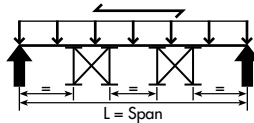

L/240

Dcs (mm)	1 Frame			2 Frame		
	0.60 BMT	0.75 BMT	1.00 BMT	0.60 BMT	0.75 BMT	1.00 BMT
100	[5,300]	[5,600]	[6,000]	[8,700]	[9,150]	[9,750]
110	[5,200]	[5,500]	[5,900]	[8,550]	[9,000]	[9,600]
120	[5,100]	[5,400]	[5,800]	[8,400]	[8,850]	[9,450]
130	[5,000]	[5,300]	[5,700]	[8,250]	[8,700]	[9,300]
140	4,900	[5,200]	[5,600]	[8,100]	[8,550]	[9,150]
150	4,800	5,100	[5,500]	[7,950]	[8,400]	[9,000]
160	4,800	5,000	5,400	[7,950]	[8,250]	[8,850]
170	4,700	5,000	5,300	[7,800]	[8,250]	[8,700]
180	4,700	4,900	5,300	[7,800]	[8,100]	[8,700]
190	4,600	4,800	5,200	[7,650]	[7,950]	[8,550]
200	4,600	4,800	5,100	[7,650]	[7,950]	[8,400]
210	4,500	4,700	5,100	[7,500]	[7,800]	[8,400]
220	4,500	4,700	5,000	7,500	[7,800]	[8,250]
230	-	4,600	5,000	-	7,650	[8,250]
240	-	4,600	4,900	-	7,650	8,100
250	-	4,600	4,900	-	7,650	8,100

The Fielders Range of User and Installation Guides



The product information presented in this brochure is intended as a guide only. It is recommended that you obtain qualified expert advice when seeking confirmation of product application. More comprehensive information can be sourced from Specifying Fielders - KingFlor Manual and KingFlor Designer Suite Software.

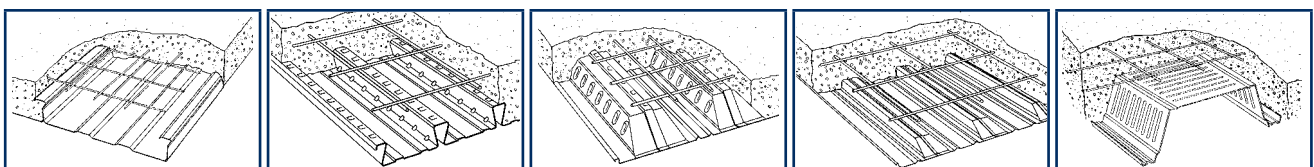

KF57®

RF55®

KF70® SquashCut™

KF40® SquashCut™

CF210®

is a registered trademark of Corus



FINISH ON TOP WITH FIELDERS

Phone Fielders First 1800 182 255 www.fielders.com.au

ADELAIDE · MELBOURNE · SYDNEY · PERTH · BRISBANE · DARWIN